

NOTES

- a. ALL DIMENSIONS ARE IN INCHES, [] = MM
- b. RECOMMENDED TORQUE FOR MOUNTING SCREWS: 6-9 LBS

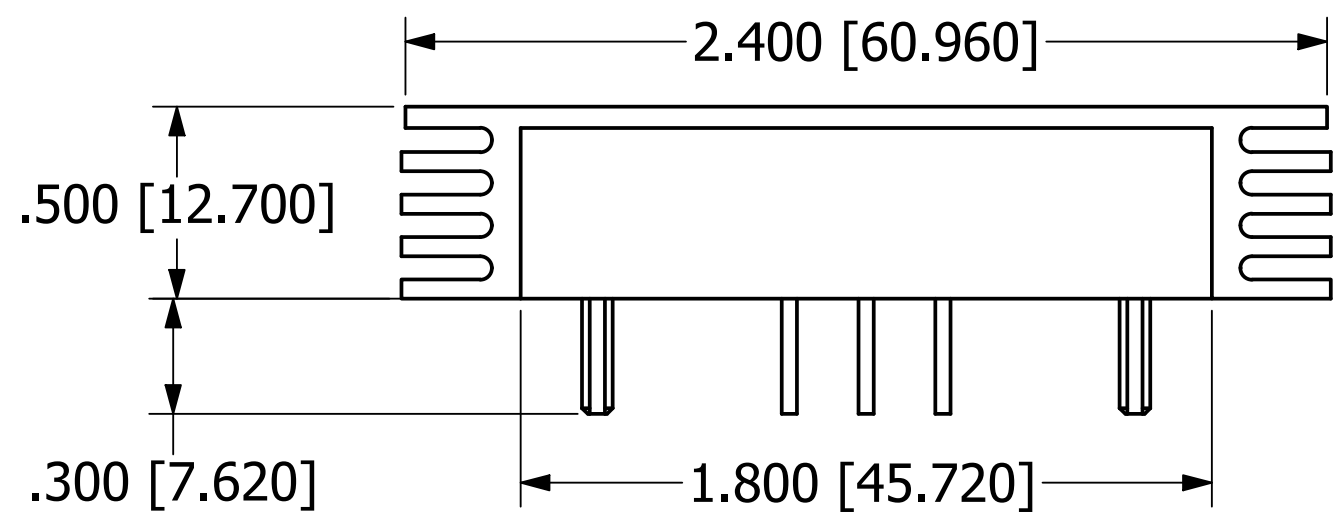

PIN NO.	SINGLE	PIN DIA.
1	+IN	.040
2	TRIM DOWN	.040
3	TRIM	.040
4	SHUT DOWN	.040
5	-IN	.040
6	-OUT	.080
7	+OUT	.080

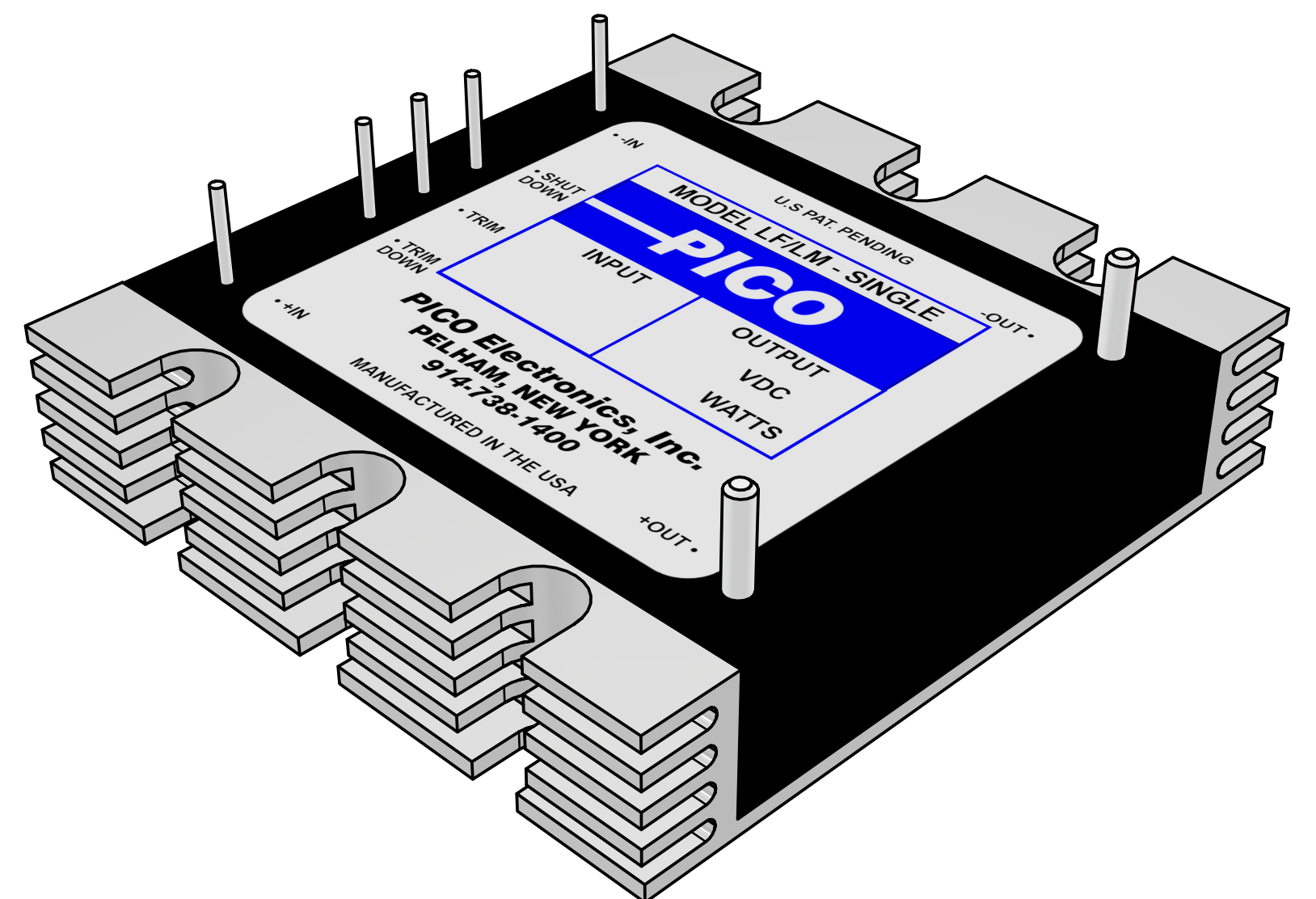
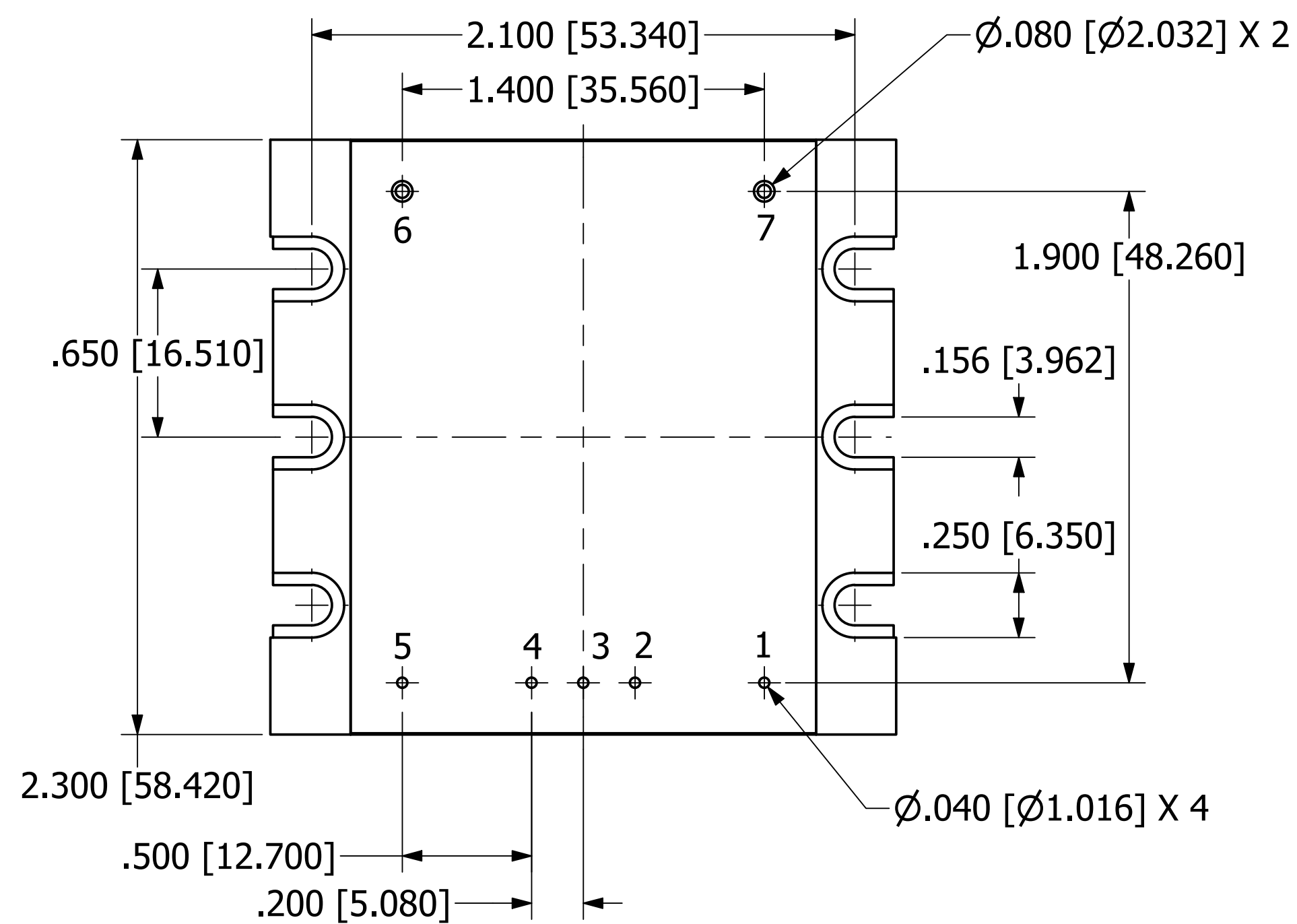

BOTTOM VIEW

PROPRIETARY AND CONFIDENTIAL

THE INFORMATION CONTAINED IN THIS DRAWING IS THE SOLE PROPERTY OF PICO ELECTRONICS INC. ANY REPRODUCTION IN PART OR AS A WHOLE WITHOUT THE WRITTEN PERMISSION OF PICO ELECTRONICS INC. IS PROHIBITED

DRAWN	P.PALUCH	PICO	143 Sparks Ave	
CHECKED	H. VIDAURRE		Village of Pelham, NY 10803	
QA		Electronics		
MFG		SERIES LF/LM - SINGLE		
APPROVED				
REVISION DATE	06/06/2023	SIZE	DWG NO	REV
		C		1
		SCALE	NTS	www.picoelectronics.com